

LE10

The LE10 (10,000 lb. capacity) 2-post lift features Challenger's innovative 3-stage front and 2-stage rear arms, which provide technicians with the versatility to lift vehicles both symmetrically and asymmetrically within the same service bay, increasing efficiency and potential revenue.

With double telescoping screw pads, durable powder coat finish and plated arm restraints and pins, the LE10 accommodates the rigorous demands of a full-service facility. Raise it even higher with optional column height extensions, which provide an additional 2 feet of overhead clearance. Lifts are available in red or blue.

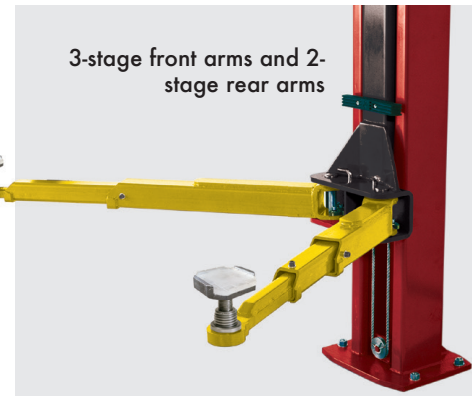

LE10 | 10,000 LB. CAPACITY

- » 2-post symmetric/asymmetric lift
- » 3-stage front and 2-stage rear arms

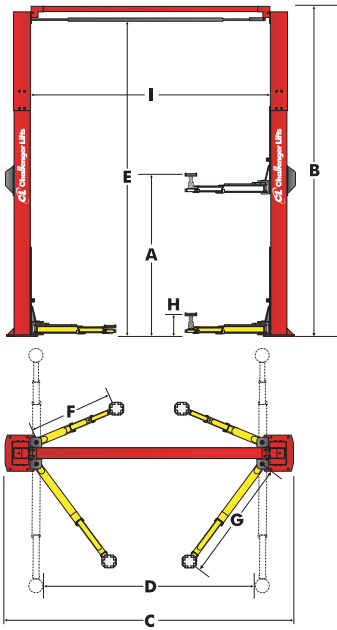

FEATURES & BENEFITS

- » 3-stage front arms and 2-stage rear arms provide a wide arm sweep for asymmetric or symmetric lifting in the same service bay
- » 11' 11.875" standard height fits in service bays with 12' ceiling height
- » Double telescoping screw pads with rubber foot pads
- » Padded overhead shut-off system prevents vehicle damage
- » Jacketed pulley-less single-point mechanical lock release system that was once exclusive to our CL series lifts are now standard on the LE10
- » Rubber door guards protect vehicle from door damage
- » Premium powder coat finish provides long-lasting durability
- » Plated arm restraints and arm pins inhibit rust and provide long-lasting durability

OPTIONAL ACCESSORIES



2' column height extensions accommodate higher profile vehicles



Air electric work station



Stack adapter kit:
 (4) 3" stack extensions
 (2) 6" stack extensions
 (2) Organizer racks

Model Number	LE10	LE10EH2** with height extensions
Lifting Capacity*		10,000 lbs.
A Rise Height ¹		74.75"
B Overall Height	11' 11.875"	13' 11.875"
C Overall Width		10' 11.75"
D Drive-Thru Clearance		98.375"
E Floor to Overhead Switch	137"	161"
F Arm Reach (Min.)		Front arm 21.75" / rear arm 38.75"
G Arm Reach (Max.)		Front arm 39.25" / rear arm 55.375"
H Screw Pad Height		4.5" - 6.75" ²
Adj. Adapter Height(with 3" extensions and screw pad)		7.5" - 9.75"
Adj. Adapter Height (with 6" extensions and screw pad)		10.5" - 12.75"
I Inside Columns		110.25"
Motor /		2HP, Single Phase, 60Hz, 208 - 230v
Speed of rise		50 s
Max. Load Per Arm		2,500 lbs.
Ceiling Height Required	12'	14'

*Lift capacity ratings are based on loads equally distributed on all four arms ¹ Rise height measured with telescoping screw pad in highest position ** Specifications are for lift model LE10 with optional accessory LE10EH2 column height extensions (must order both LE10 and LE10EH2 for new lift purchase or LE10EH2 for addition of 2' height extension to an existing lift ² Specifications are listed without rubber pad, for measurements with rubber pad add 0.25"

For more information, contact your Authorized Challenger Lifts Distributor:

